



“Gheorghe Asachi” Technical University of Iasi, Romania



PARTITIONING DYNAMICS AND FATE OF METALS IN AN URBAN WASTEWATER TREATMENT PLANT

Giancarlo Cecchini*, Paolo Cirello, Biagio Eramo

Acea Elabiori SpA, 165 Via Vitorchiano, 00189 Roma, Italy

Abstract

This study focused on the fate of the most representative metals in urban wastewater treatment by the conventional activated sludge process. The research analyzed: distribution between soluble and particulate fraction in the different treatment stages, removal efficiencies as related to partitioning, and metal behavior during rainfall events. A mass balance approach allowed evaluating the behavior of the metals, migration between phases and final fate, in order to investigate metal dynamics during the treatment cycle. Metal distribution between phases in outflow fluxes (treated effluent and sludge) resulted consistent with their partitioning between soluble and particulate fraction in the influent and significant migration between phases was not observed. Arsenic was found to be the most critical element for sludge reuse, despite being mostly partitioned into the soluble fraction.

Key words: activated sludge, arsenic, metals, sludge reuse, wastewater treatment

Received: December, 2014; *Revised final:* June, 2015; *Accepted:* June, 2015

1. Introduction

Over the last thirty years, the approach to wastewater treatment has been aimed at improving treated effluent quality, according to regulatory developments and given the increased sensitivity to environmental issues and to the protection of water resources.

Numerous studies have focused on the enhancement of secondary treatment efficiency and the implementation of tertiary processes, such as disinfection and/or refinement of treated water for reuse purposes. As a secondary effect, these innovations have inevitably led to an increase of sludge production per population equivalent (Fytilli and Zabaniotou, 2008; Kelessidis and Stasinakis, 2012).

More recently, also by reason of tightening of regulations on landfill disposal and more stringent requirements for agricultural and energetic reuse, technologies aimed at reducing sludge production

and improving its quality, in order to promote recovery/reuse are gaining increasing interest.

In this sense, it is essential a better understanding of partitioning dynamics and removal processes of potential pollutants, such as metals, and to investigate on the possibility of adopting targeted measures, aimed at reducing their concentrations in sludge. However, given the conservative behavior of metals, migration between phases does not result in removal but simply in a transfer of the impacted area from the solid matrix to the receiving water body, which should therefore be assessed in relation to the overall environmental benefits.

2. Outline of the work

On the basis of European and Italian regulations, wastewater sludge is classified according to the European Waste Catalogue (EWC, 2002) with the Code 19 08 05 (“Sludge from treatment of urban waste water”).

In Italy, landfilling has been the most widely used method for wastewater sludge disposal (EC,

* Author to whom all correspondence should be addressed: e-mail: g.cecchini@aceaspa.it; Phone: +39 06 57992621; Fax: +39 06 57992629

2010), until recent regulations (Decree, 2005) introduced more stringent measures. In light of the new standards, landfill disposal of urban wastewater sludge is expected to cease, because of Total Organic Carbon (TOC) content in sludge and of Dissolved Organic Carbon (DOC) concentration in the eluate; anyway, the impossibility to apply the new rules immediately has led to grant extensions in order to implement interventions and organize alternative reuse systems and strategies.

Wastewater sludge management is thus a highly relevant and important issue, also because of the energetic and agronomic properties of the sludge itself. Sludge reuse in agriculture as a soil conditioner is viewed positive because of the organic matter and nutrient contents, and it can be carried out by two different techniques: a) direct spreading on the soil, after stabilization processes and if complying with chemical-physical requirements set by EC Directive (1986) and its national transposition, the Italian Legislative Decree n. 99/1992 (Decree, 1992). Similarly, the calorific value of the organic matter makes wastewater sludge suitable for energy recovery and therefore to be treated by dedicated waste to energy plants, or in co-combustion with other fuels.

In this case, in systems operating according to the simplified procedure, sludge combustion is allowed after compliance with the requirements set by the technical standards of the Decree of the Italian Environment Ministry 05/02/1998 (Decree, 1998). Both for agricultural reuse and energy recovery purposes some issues are posed, on one hand concerning the safety of agricultural products and of the workers employed in spreading operations and the other hand related to the potential environmental impacts. EC Directive (1986) on agricultural land treatment is currently under revision, and a tightening of limits and a review of the parameters could be introduced; moreover, some Italian regions (Emilia Romagna, Lombardia) have already issued

supplementary regulations to the national laws, by introducing additional inorganic and organic parameters and restricting some of the quality standards.

Heavy metals represent the category of parameters more involved in the above revision processes, as a consequence of their characteristic tendency to accumulate; gaining a better understanding of their presence and behavior is therefore essential, in order to address sludge management strategies, also in relation to the evolution of the regulatory framework concerning the different reuse systems.

3. Case study

The main object of the current study was to investigate dynamics and final fate of the most representative metals in conventional wastewater processes, such as the activated sludge systems. Based on a mass balance approach, partitioning between soluble and particulate fraction and distribution in the different treatment stages were considered, in order to evaluate removal efficiency, behavior, migration between phases and final fate in the output flows of the systems.

Behavior during rainfall events has also been studied. The study was carried out at a wastewater treatment plant (WWTP) located in Rome metropolitan area, with average input flow-rate 3.0 m³/sec; treated effluent is discharged into the Tiber river.

The water line is made of a pretreatment stage and two identical process trains, each including two parallel primary clarifiers, an activated sludge unit and two parallel secondary clarifiers. The sludge line includes pre-thickening, anaerobic digestion (not operating during the study), post-thickening and dehydration with centrifuges. Fig. 1 describes the process diagram of the WWTP showing the location of the sampling points.

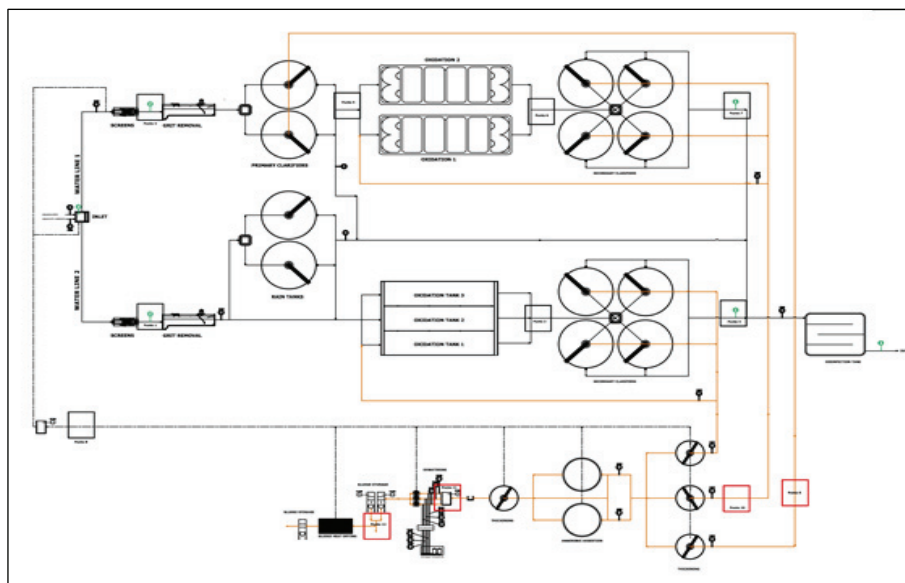

Fig. 1. Process diagram of the wastewater treatment plant

4. Material and methods

Monitoring campaigns based on regular and systematic sampling of influent, treated effluent and sludge were carried out, weekly/fortnightly, for a period of 15 months. Composite samples were taken, constituted by the assembling of subsamples collected on a hourly basis by means of automatic samplers. At the same time, discrete samples were also drawn, in order to assess comparability between the average data collected through composite and discrete sampling. Discrete sampling on the water treatment line and sludge was carried out according to international methods (APHA-AWWA-EF, 2005).

Wastewater samples were taken at 8 monitoring points: influent; effluent from primary sedimentation (first and second train); effluent from activated sludge unit (first and second train); effluent from secondary sedimentation (first and second train); treated effluent.

Sludge samples were collected at 4 locations: secondary sludge from first and second train; inlet and outlet of dehydration. Supernatants from the sludge treatment line were also sampled. Altogether for each sampling campaign 13 treatment stages were monitored; a total of 28 campaigns were carried out. Analyses were performed with methods accredited by the Italian accreditation body Accredia under UNI CEI EN ISO/IEC 17025 Quality Procedures.

Table 1 lists analytes, methods and related quantification limits (LOQ), both for water and sludge samples. Dissolved metals were determined after filtration of the sample through 0.45 µm filters.

During monitoring campaigns, flow-rate data of the main fluxes of both the water and the sludge treatment lines were collected.

5. Results and discussion

5.1. Influent

Table 2 shows metal concentrations in the influent both for discrete and composite samples. For statistical purposes, concentrations below the detection limits were taken as equal to the detection limit itself.

Comparison of analytical results from composite and discrete samples shows that concentrations found are in a strictly close agreement, which is consistent with what might be expected for an urban wastewater treatment plant receiving no anthropogenic inputs from industrial activities. Metal concentrations in the influent were extremely low, such as to comply or at least be comparable with quality standards set for drinking water (EC Directive, 1998). The graph below (Fig. 2), in logarithmic scale to allow visualization of the trends for all parameters, compares statistical figures (minimum, maximum, average, median) of influent composite samples with quality standards for drinking water.

5.2. Treated effluent and metal removals efficiency

Table 3 shows treated effluent concentrations of metals both for discrete and composite samples.

Table 1. Parameters, analytical methods and instrumental detection limits

	<i>WATER SAMPLES</i>		<i>SLUDGE SAMPLES</i>	
	<i>LOQ µg/L</i>	<i>Method</i>	<i>LOQ mg/kdDW</i>	<i>Method</i>
Cu	1.0	APHA SM2005 3030K+3125	1.0	EPA 3052 1996+EPA 6010 C 2007
Pb	0.2	APHA SM2005 3030K+3125	1.0	EPA 3052 1996+EPA 6010 C 2007
Ni	2.0	APHA SM2005 3030K+3125	1.0	EPA 3052 1996+EPA 6010 C 2007
Zn	1.0	APHA SM2005 3030K+3125	1.0	EPA 3052 1996+EPA 6010 C 2007
Cd	0.2	APHA SM2005 3030K+3125	1.0	EPA 3052 1996+EPA 6010 C 2007
Cr	5.0	APHA SM2005 3030K+3125	1.0	EPA 3052 1996+EPA 6010 C 2007
As	1.0	APHA SM2005 3030K+3125	4.0	EPA 3052 1996+EPA 6010 C 2007
Hg	0.2	EPA 7473 2007	0.001	EPA 7473 2007
Mn	0.2	APHA SM2005 3030K+3125	1.0	EPA 3052 1996+EPA 6010 C 2007

Table 2. Metal concentrations in WWTP influent

<i>Concentration (µg/L)</i>		Cu	Pb	Ni	Zn	Cd	Cr	As	Hg	Mn
<i>WWTP INFLUENT Discrete Samples</i>	<i>Minimum</i>	9.1	2.9	1.4	44.7	0.2	5.0	3.3	0.2	34.4
	<i>Average</i>	26.4	12.5	3.5	105.2	0.2	5.5	5.0	0.2	90.4
	<i>Maximum</i>	63.4	32.9	7.6	216.2	0.3	10.5	8.8	0.5	213.4
	<i>Median</i>	23.5	11.8	2.8	95.4	0.2	5.0	4.8	0.2	83.7
<i>WWTP INFLUENT Composite Samples</i>	<i>Minimum</i>	5.9	2.2	1.3	31.1	0.2	5.0	3.0	0.2	29.9
	<i>Average</i>	31.4	12.8	4.4	195.2	0.2	5.8	4.9	0.5	90.8
	<i>Maximum</i>	98.6	41.5	8.6	841.6	0.6	11.1	10.2	6.1	159.2
	<i>Median</i>	23.4	9.0	3.8	109.0	0.2	5.0	4.8	0.2	88.0

Table 3. Metal concentrations in WWTP effluent

Concentration ($\mu\text{g/L}$)		Cu	Pb	Ni	Zn	Cd	Cr	As	Hg	Mn
WWTP EFFLUENT Discrete Samples	<i>Minimum</i>	1.0	0.3	1.0	7.9	0.2	5.0	2.7	0.2	14.8
	<i>Average</i>	5.8	2.6	2.6	37.3	0.2	5.0	3.7	0.2	61.6
	<i>Maximum</i>	14.7	6.0	10.0	68.6	0.2	5.5	5.2	0.4	110.8
	<i>Median</i>	5.1	2.5	2.2	34.0	0.2	5.0	3.6	0.2	62.4
WWTP EFFLUENT Composite Samples	<i>Minimum</i>	1.0	0.2	1.0	2.2	0.2	5.0	1.0	0.2	1.9
	<i>Average</i>	5.9	2.8	3.6	37.1	0.2	5.0	3.6	0.2	63.6
	<i>Maximum</i>	15.8	6.2	39.6	71.8	0.2	6.3	4.9	0.5	97.3
	<i>Median</i>	5.7	2.8	2.3	36.9	0.2	5.0	3.4	0.2	61.9
EFFLUENT LIMITS (discharge in surface water)		<i>Parametric value</i>	400	300	4,000	1,000	20	4,000	500	4,000

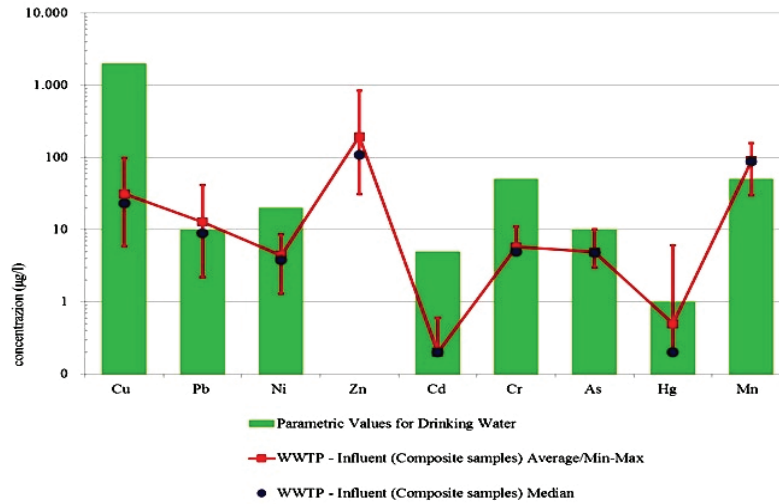

Fig. 2. Comparison between drinking water quality standards (EC Directive, 1998) and values in WWTP influent

Treated effluent concentrations were low, with values significantly below the standards for discharge into surface water (EC Directive, 1998). Average concentrations were lower than the limits by a factor, dependent on the metal, ranging from 15 for Zinc and 1,000 for Nickel.

Fig. 3 shows overall removal efficiency in the liquid stream, based on composite sample results, for all metals except for cadmium and mercury, whose concentrations both in influent and treated effluent samples often resulted lower than the instrumental detection limit.

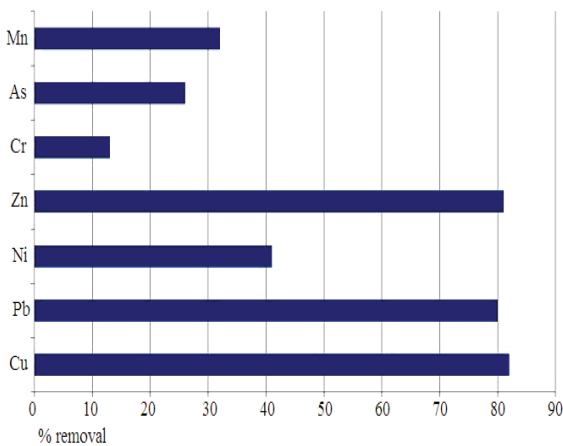

Fig. 3. Overall removal efficiencies of WWTP

Removal computed from discrete samples exhibited a similar trend. The chart shows that, despite urban wastewater treatment plants are not designed for removing metals, significant removal efficiencies are obtained, especially for lead, zinc, and copper.

5.3. Dewatered sludge

The analysis of the residual solid fraction shows that, contrary to results for the treated effluent, in which concentrations were significantly below discharge standards, in sludge average values were close to the levels allowed for reuse (Table 4). Concentrations found are in good agreement with other studies (Chipasa, 2003; Hoss et al., 2001; Mayr, 2005).

Data show as many parameters can often reach critical concentrations, especially arsenic, which was found to constantly exceed the standards for energy reuse and specific standards set by some Italian regions for agronomic use.

To verify the representativeness of the data acquired from the treatment plant considered by the present study, they were also compared to the average values obtained from WWTPs of the same territorial context and similar capacity and process diagrams (Fig. 4); the graph shows that the values taken from different treatment facilities were fully comparable.

Table 4. Results in dewatered sludge

Concentration (mg/kgDW)	Cu	Pb	Ni	Zn	Cd	Cr	As	Hg	Mn
Average	279	128	29	758	1.3	34	12	1.2	203
Median	250	124	25	722	1.3	33	13	1.2	177
Land Application, EU; Directive 1986/278/EEC	1,000÷1,750	750÷1,200	300÷400	2,500÷4,000	20÷40	-	-	16÷25	-
Land Application, Italy; Legislative Decree 99/1992	1,000	750	300	2500	20	-	10 ⁽¹⁾	10	-
Incineration, Italy; Environment Decree 05/02/98	300	200	40	-	7 ⁽²⁾	100	9	7 ⁽²⁾	400
Secondary solid fuels; CTI (2012) – Recommendation 8/2012	2,000	600	200	-	10	500	15		600

(1) Regional limits Emilia Romagna (DRG 285, 2005); (2) Sum Cd + Hg

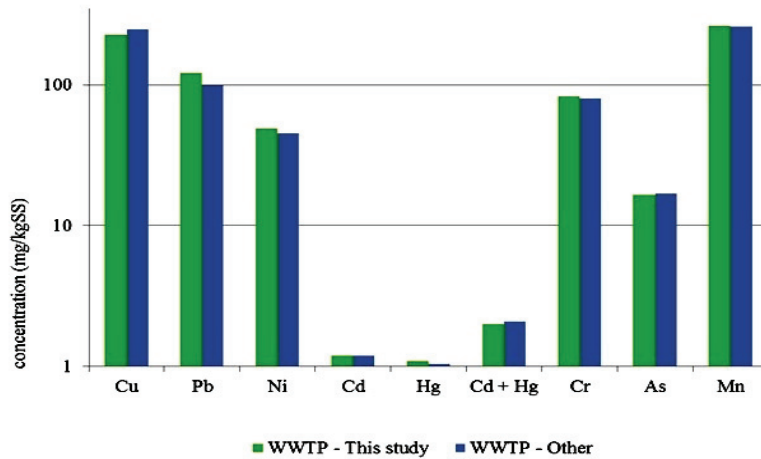

Fig. 4. Metal concentrations in sludge from this study compared with results from another WWTP

5.4. Influence of polyelectrolyte

In order to investigate on possible contribution to the concentration of metals in sludge from polyelectrolyte used in sludge treatment, a sample of polyelectrolyte was analyzed. Table 5 shows obtained results in the polyelectrolyte and its relative contribution to the metal content in sludge, computed based on quantities used daily. As shown, the contribution of polyelectrolyte can be considered negligible in comparison to the average concentrations in sludge.

Table 5. Metal contributions from polyelectrolyte

Metal	POLYELECTROLYTE Concentration (mg/kg)	DEWATERED SLUDGE Contribution from polyelectrolyte (mg/kgDW)
As	<1	0.005
Cd	<0.25	0.001
CR	0.528	0.003
Cu	11.3	0.061
Pb	3.92	0.021
Mn	0.5	0.003
Ni	<0.25	0.001
Zn	16	0.086
Fe	13.5	0.073

5.5. Metal concentrations during rainfall events

In order to investigated metal behavior during rainfall events, a collector-sewer to the treatment plant was monitored during a forecasted intense rainfall, following a dry weather period. Monitoring was carried out between 6.30 - 13.30, sampling wastewater with an automatic device every 20 minutes. During the event there was a peak of 100 mm rainfall at 8.30. Trends resulted for the various metals are shown in Fig. 5.

All metals showed a significant increase in concentration during the monitored period; maximum values were observed two hours after the rainfall peak, and levels higher than reference value recorded during dry weather conditions continued for a few hours.

By analyzing the concentrations of individual metals in the observation period the following trends were found:

- zinc and copper showed a concentration peak 20 times higher than the average value during dry weather;
- arsenic, nickel, manganese and lead peaks exceeded by more than 100 times the average influent concentration during dry weather.

The survey found that intense rainfall events after dry weather periods cause, for limited periods,

significant increases of metal contents in WWTP influents.

These increases, anyway, were not reflected on metal concentrations of treated effluent composite sample and sludge, for two reasons:

- by reason of the hydraulic residence time of the system and of the production time span of dehydrated sludge;
- because of the dilution determined by rain events in the medium term.

5.6. Metal partitioning between soluble and particulate fraction

In order to understand removal mechanisms, partitioning of each metal between soluble and particulate fraction in influent and effluent was determined. Average values on composite samples are shown in Fig. 6.

Fig. 7 compares, for each metal, the percent fraction of soluble and particulate metals in the raw influent with the overall percent removal efficiency of the treatment plant.

Cadmium and mercury are not represented, as their concentrations in the influent were lower than instrumental detection limits. Removal efficiencies are evidently linked to the removal of the particulate fraction, in it self associated with the reduction of Total Suspended Solids (TSS); the amount not removed is clearly connected with the dissolved fraction, which remains in the treated effluent.

Keeping into account metal partitioning between soluble and particulate fraction in both influent and treated effluent, the Figs. 6 - 7 show that the dissolved fraction, indeed, for all metals considered by this study does not undergo significant changes with treatment. Manganese represents the only significant or most marked exception, since a part of its dissolved fraction is removed.

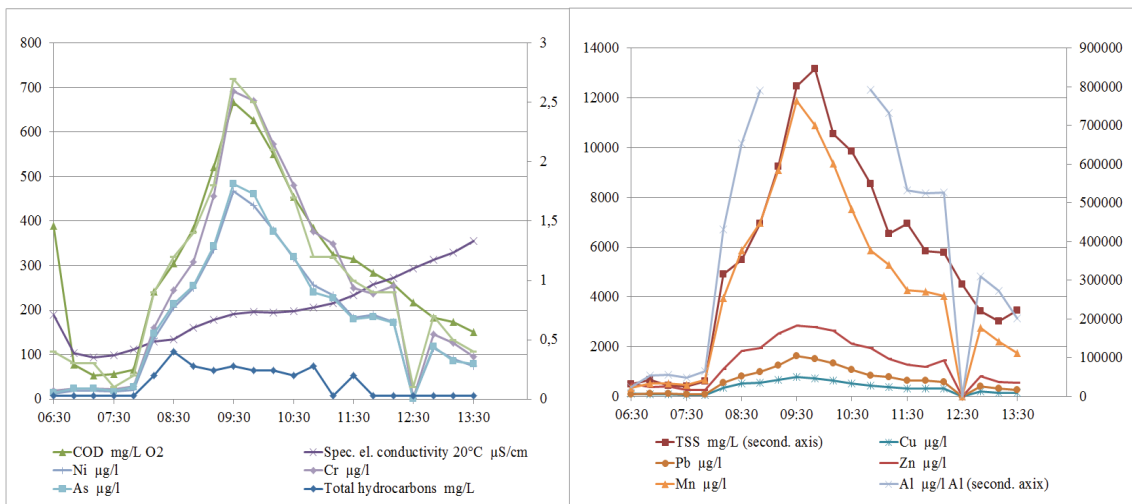

Fig. 5. Metal concentrations in WWTP influent during intense rainfall

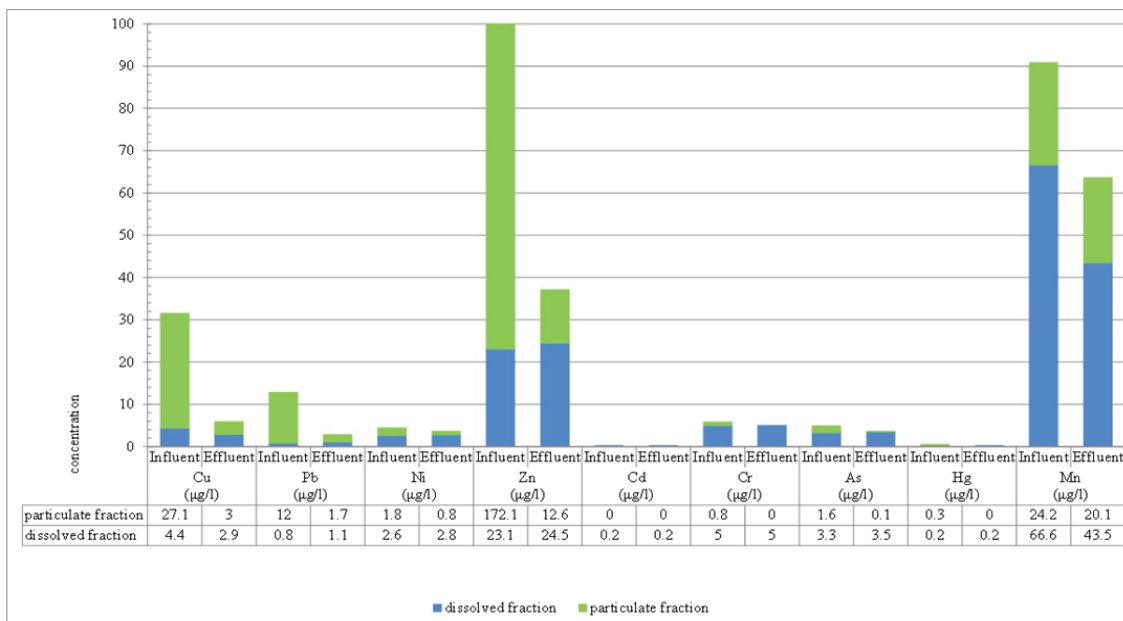

Fig. 6. Metal partitioning in WWTP influent and effluent

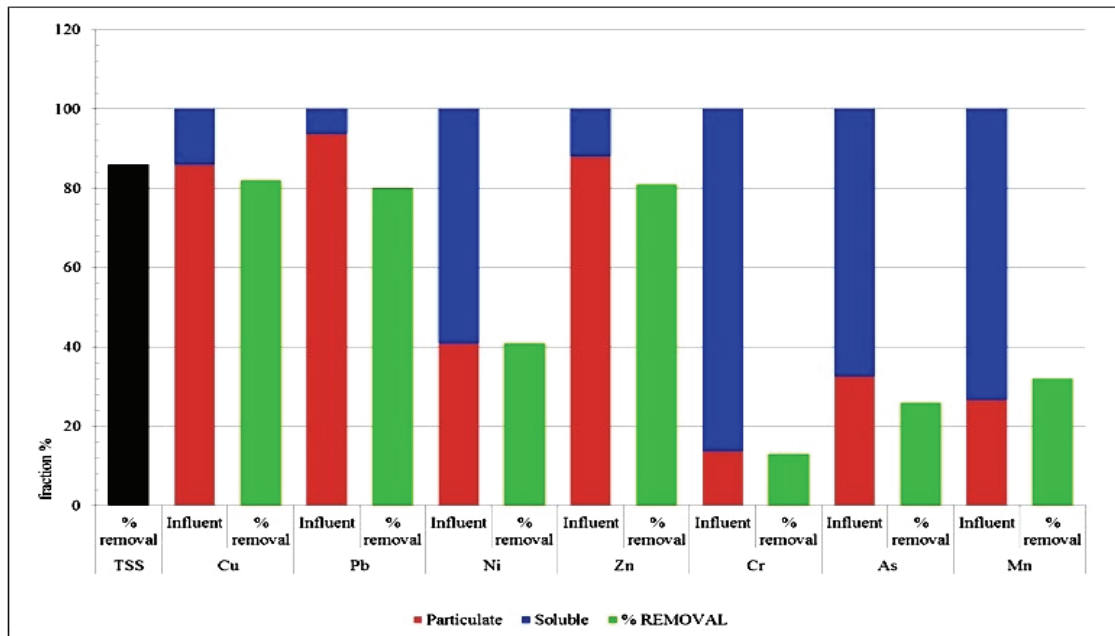

Fig. 7. Metal partitioning in WWTP influent and removal efficiency

5.7. Mass balances

Given the close agreement between data from composite and discrete samples, the discussion of the results of mass balances and partitioning between dissolved and particulate phase will be presented by analyzing the results from the composite samples only. Mass balances were drawn for each metal, based on the average flow-rate values taken at the different plant units, and on the average concentrations detected over the course of monitoring. Overall results are summarized hereafter (Table 6).

Table 7 shows, for each metal, influent and effluent loads of the WWTP, partitioned between dissolved and particulate phases, both as kg/d and percentage. Influent and treated effluent loads are computed based on the results of composite samples.

With reference to the mass balances, percentage distributions of the metals in the output flows (treated effluent and dewatered sludge) were found, as shown in Fig. 8.

Metal behavior was found consistent with their partitioning between the soluble and particulate fractions in influent wastewater; this allowed defining four different clusters:

- CLUSTER 1 - copper, lead and zinc: these metals showing a predominant distribution in the particulate phase (around 70-80%) and high tendency to accumulate in sludge;

- CLUSTER 2 - arsenic, manganese and chromium: characterized by being partitioned mostly in the soluble phase (about 70-90%), were mainly found in the effluent;

- CLUSTER 3 - nickel: exhibited an intermediate behavior, being equipartitioned between particulate and soluble fraction;

- CLUSTER 4 – mercury and cadmium: they cannot be classified, as generally present at concentrations below the detection limits.

With reference to the process chain considered in this work and based on mass balances and removal efficiencies, the data below (Table 8) show how influent concentrations of metals are distributed in the two output flows. Besides, it also allows highlighting the influent concentrations that produce metal concentrations found in dewatered sludge.

Arsenic was found mostly partitioned in the soluble phase of plant influent (74%) and its contribution to the sludge content was only 26% of the input loading. Despite this, because of the stringent quality standards set by some Regional authorities, mass balances indicate that with average influent values around 6 µg/L, a transfer of 1-2 µg/L to the sludge is enough produce non-conformity with quality standards set for agronomic or energy reuse.

6. Discussion

Ziolko et al. (2011), in their extensive review, highlighted the scarcity of recent studies on metal removal efficiency in the activated sludge process, and that both metal concentrations and their partitioning between soluble and particulate phases in influent wastewater have been found to be rather variable in different locations. Some recent data on metal concentration in dewatered sludge from urban wastewater treatment plants are reported in Table 9.

Concentrations appear highly variable especially for copper, nickel and chromium; data from this study are mostly in the low-middle range, except for arsenic, whose average value is very close to that found by Van der Velden et al. (2008).

Table 6. Metal mass loadings in WWTP influent and effluent

	<i>Cu</i> (kg/d)	<i>Pb</i> (kg/d)	<i>Ni</i> (kg/d)	<i>Zn</i> (kg/d)	<i>Cr</i> (kg/d)	<i>As</i> (kg/d)	<i>Mn</i> (kg/d)
WWTP influent (Avg composite sample)	8.14	3.33	1.14	50.60	1.49	1.28	23.54
WWTP effluent (Avg composite sample)	1.54	0.72	0.94	9.61	1.31	0.93	16.48
Dewatered sludge	7.40	3.38	0.76	20.09	0.90	0.33	5.39

Table 7. Metal loading and partitioning in influent and effluent (composite samples)

	<i>Cu</i>	<i>Pb</i>	<i>Ni</i>	<i>Zn</i>	<i>Cr</i>	<i>As</i>	<i>Mn</i>
Partitioning							
Influent - particulate (kg/d)	7.01	3.12	0.48	44.61	0.20	0.42	6.27
Influent – soluble (kg/d)	1.13	0.21	0.66	5.99	1.30	0.85	17.26
Effluent - particulate (kg/d)	0.79	0.44	0.21	3.25	0.01	0.02	5.19
Effluent – soluble (kg/d)	0.75	0.28	0.74	6.36	1.30	0.91	11.29
Percent partitioning							
Influent - particulate %	86%	94%	42%	88%	13%	33%	27%
Influent – soluble %	14%	6%	58%	12%	87%	67%	73%
Effluent – particulate %	51%	61%	22%	34%	1%	2%	32%
Effluent – soluble %	49%	39%	78%	66%	99%	98%	68%

Table 8. Concentration and daily loads in WWTP input and output flows

			<i>Cu</i>	<i>Pb</i>	<i>Ni</i>	<i>Zn</i>	<i>Cr</i>	<i>As</i>	<i>Mn</i>
INPUT	WWTP Influent	Avg conc. comp. sample (µg/L)	31.4	12.8	4.4	195.2	5.8	4.9	90.8
		Daily load (kg/d)	8.14	3.33	1.14	50.60	1.49	1.28	23.54
OUTPUT	WWTP Effluent	Avg conc. comp. sample (µg/L)	5.9	2.8	3.6	37.1	5.0	3.6	63.6
		Daily load (kg/d)	1.54	0.72	0.94	9.61	1.31	0.93	16.48
	Dewatered sludge	Avg conc. (mg/kg DW)	279	128	29	758	34	12	203
		Daily load (kg/d)	7.40	3.38	0.76	20.09	0.90	0.33	5.39

Table 9. Metal concentration in dewatered sludge (mg/kgDW)

	<i>Cu</i>	<i>Pb</i>	<i>Ni</i>	<i>Zn</i>	<i>Cd</i>	<i>Cr</i>	<i>As</i>	<i>Hg</i>	<i>Mn</i>
This study	279	128	29	758	1.3	34	12	1.2	203
Van der Velden et al. (2008)	300	162	38.7	1581	4.5	85	10.5	1.1	-
Zorpas et al. (2011)	141.9	82.0	15.55	287.6	0.775	11.01	-	-	177.3
Guillemet et al. (2009)	238.9	81.2	22.5	934.6	3.0	47.8	3.5	1.2	-
Bright and Healy (2003)	1300	96	68	760	5.7	91	6.1	-	-
da Silva Oliveira et al. (2007)	391.7	132.1	239.4	864.4	1.34	195.0	1.14	0.31	208.1
Höss et al. (2001)	278.89	96.61	61.59	1320.60	2.88	88.27	-	-	-
Dimitriou et al. (2006)	770	36	21	875	1.8	27	-	-	-
Hernández-Sánchez et al. (2013)	37.05	26.44	8.04	544.01	-	24.10	-	-	-

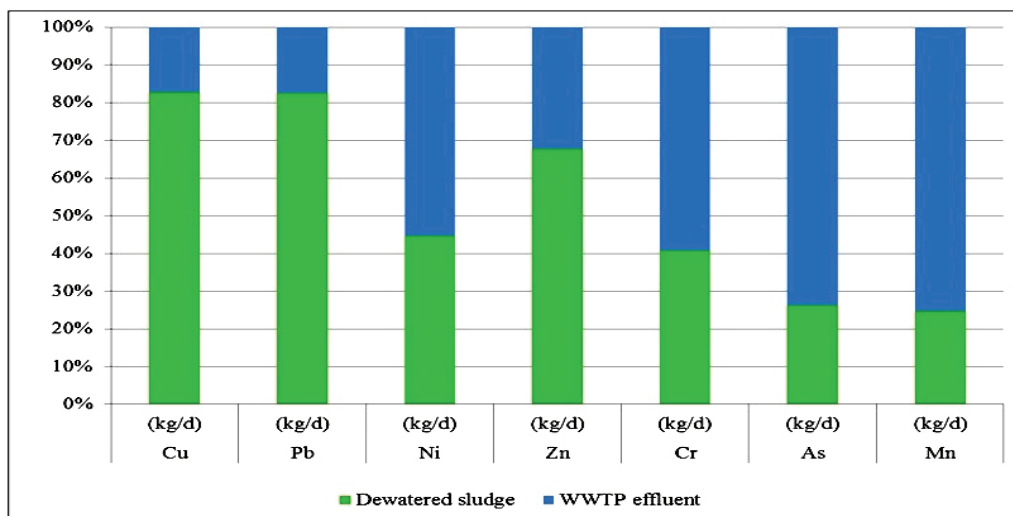

Fig. 8. Metal distribution in WWTP effluent and dewatered sludge

Buzier et al. (2006), on a large size activated sludge plant, found that after secondary treatment lead and copper, mostly distributed in the particulate phase, were removed with efficiencies around 70%, whilst nickel removal efficiency was found to be about 25%. These removal efficiencies are slightly lower than the ones in the present study, in which, anyway, percent particulate fractions were found higher.

Petrie et al. (2014) on a pilot scale activated sludge plant found zinc, copper and lead removal efficiency up to 70-80%, depending on both hydraulic and sludge retention time.

Manganese removal efficiency is highly variable and recent literature reports values in the range 10÷50% (Gulyás et al., 2014; Silva Oliveira et al., 2007). In this study manganese was the only metal with the soluble fraction significantly affected by treatment, as shown in Fig. 6; dissolved manganese is indeed subjected to change in oxidation state from soluble Mn(II) to insoluble Mn(IV) during aerobic treatment, this allowing to improve removal (Karvelas et al., 2003).

7. Conclusions

Average metal concentrations in plant influent and treated effluent were found extremely low. The study confirms previous findings that metal partitioning between soluble and particulate phases plays a key role on their removal efficiency in activated sludge process. Mass balances based on partitioning show that output fluxes respectively to receiving waters (liquid stream) and sludge are in most cases consistent with metal distribution between the soluble and particulate phases in raw wastewater. Migration between phases was not observed for any metal, with the exception of manganese, whose dissolved fraction was significantly removed (about 35%) from the liquid stream.

Results on dewatered sludge highlight possible critical situations, particularly with respect to the concentrations of arsenic, although the concentration of arsenic removed from the influent and transferred to the sludge was only 1-2 µg/L.

Alternative treatment chains or dedicated units could transfer critical metals from the solid to the liquid phase; anyway, these options should be assessed in relation to the overall environmental benefit.

Acknowledgements

The authors wish to thank Laura Diaco for her significant contribution in data analysis and assistance in writing this paper.

References

APAT, IRSA-CNR, (2003), Analytical methods for water, APAT Manuali e Linee Guida 29/2003, Roma 2004.

- APHA, AWWA, WEF, (2005), *Standard Methods for the Examination of Water and Wastewater*, XX ed. American Public Health Association, Washington DC.
- Bright D.A., Healy N., (2003), Contaminant risks for biosolid land application: contemporary organic contaminant levels in digested sewage sludge from five treatment plants in Greater Vancouver, British Columbia, *Environmental Pollution*, **126**, 39-49.
- Buzier R., Tusseau-Vuillemin M.H., dit Meriadec C.M., Rousselot O., Mouchel J.M., (2006), Trace metal speciation and fluxes within a major French wastewater treatment plant: Impact of the successive treatments stages, *Chemosphere*, **65**, 2419-2426.
- Chipasa K.B., (2003), Accumulation and fate of selected heavy metals in a biological wastewater treatment system, *Waste Management*, **23**, 135-143.
- CTI, (2012), Italian Thermotechnical Committee, Recommendation 08:2012: Secondary Solid Fuels - SSF - Classification and technical specifications for derived from mechanical treatment of non-hazardous waste (in Italian), On line at: <http://shop.cti2000.it/schedadoc.php?id=88>.
- da Silva Oliveira A., Bocio A., Beltrami Trevilato T.M., Magosso Takayanagui A.M., Domingo J.L., Segura-Muñoz S.I., (2007), Heavy metals in untreated/treated urban effluent and sludge from a biological wastewater treatment plant, *Environmental Science and Pollution Research*, **14**, 483 - 489.
- Decree, (1992), Implementation of the 86/278/CEE Directive on the protection of the environment, and in particular of the soil, when sewage sludge is used in agriculture, Italian Legislative Decree No. 99/1992, Official Journal, No. 38, SO n. 28, Rome, Italy.
- Decree, (1998), Identification of non-hazardous waste subject to simplified recovery procedures, Decree 05/02/1998 of the Italian Environment Ministry, Official Journal, No. 88, SO n. 72, Rome, Italy.
- Decree, (2005), Definition of landfill waste acceptance criteria, Decree 03/08/2005 of the Italian Environment Ministry, Official Journal, No. 201, Rome, Italy.
- Decree 152, (2006), Regulations on environmental matters, Italian Legislative Decree No. 152/2006, Official Journal, No. 88, SO n. 96, Rome, Italy.
- Dimitriou I., Eriksson J., Adler A., Aronsson P., Verwijst T., (2006), Fate of heavy metals after application of sewage sludge and woodeash mixtures to short-rotation willow coppice, *Environmental Pollution*, **142**, 160-169.
- DRG 285, (2005), Preliminary guidelines to provinces on management and permission to use sludge from wastewater treatment in agriculture, Decision of the Regional Government (Emilia-Romagna) No. 285/2005 (in Italian), Official Bulletin of the Emilia-Romagna Region, PII, No. 50, Bologna, Italy.
- EC, (2010), Study on the environmental, economic and social impacts of the use of sewage sludge on land, Part III, European Commission, DG Environment under Study Contract DG Environment, Brussels, On line at: http://ec.europa.eu/environment/waste/sludge/pdf/part_iii_report.pdf.
- EC Directive, (1986), Directive 1986/278/EEC of the Council of the European Communities of 12 June 1986, on the protection of the environment, and in particular of the soil, when sewage sludge is used in agriculture, Official Journal of the European Communities, L181, 04.07.1986, Brussels.

- EC Directive (1998), Directive 1998/83/CE, on the quality of water intended for human consumption, Official Journal of the European Communities, L 330, 05/12/1998, Brussels.
- EWC, (2002), European Waste Catalogue and Hazardous Waste List, Environmental Protection Agency, Ireland.
- Fytali D., Zabaniotou A., (2008), Utilization of sewage sludge in EU application of old and new methods - a review, *Renewable and Sustainable Energy Reviews*, **12**, 116–140.
- Guillemet T.A., Maesen P., Delcarte E., Lognay G.C., Gillet A., Claustriax J.J., Culot M., (2009), Factors influencing microbiological and chemical composition of South-Belgian raw sludge, *Biotechnologie, agronomie, société et environnement*, **13**, 249–255.
- Gulyás G., Pítás V., Kárpáti A., Fazekas B., Domokos E., Rédey E., (2014), Heavy metal balance in a Hungarian municipal sewage treatment plant, *Environmental Engineering and Management Journal*, **13**, 2039-2044.
- Hernández-Sánchez C., Burgos A., Galindo J.M., Gutiérrez A., Rubio C., Hardisson A., (2013), *Heavy metal content in sewage sludge: a management strategy for an ocean island*, Proc.s 1st International Workshop, San Cristobal de La Laguna, Tenerife, Spain, 10-12 April 2013.
- Hoss T., Düring R.A., Gäth S., (2001), *Use of compost and sewage sludge with different tillage treatments for sustained soil protection*. In: *Sustaining the Global Farm*, Stott D.E., Mohtar R.H. Steinhardt G.C. (Eds.), Selected papers from the 10th International Soil Conservation Organization Meeting, May 24-29, Purdue University and the USDA-ARS National Soil Erosion Research Laboratory, 440-446, On line at: <http://topsoil.nserl.purdue.edu/nserlweb-old/isco99/pdf/ISCOdisc/SustainingTheGlobalFarm/P269-Hoss.pdf>.
- Karvelas M., Katsoyiannis A., Samara C., (2003), Occurrence and fate of heavy metals in the wastewater treatment process, *Chemosphere*, **53**, 1201-1210.
- Kelessidis A., Stasinakis A.S., (2012), Comparative study of the methods used for treatment and final disposal of sewage sludge in European countries, *Waste Management*, **32**, 1186–1195.
- Mayr B., (2005), Treatment of communal sewage sludge: quantities, recent and future technologies, heavy metals and costs, On line at: <http://www.envicare.at/wp-content/uploads/2014/09/Schlammbehandlung-skript.pdf>.
- Petrie B., McAdam E.J., Lester J.N., Cartmell E., (2014), Assessing potential modifications to the activated sludge process to improve simultaneous removal of a diverse range of micropollutants, *Water Research*, **62**, 180–192.
- Van der Velden M., Dewilb R., Baeyens J., Josson L., Lanssens P., (2008), The distribution of heavy metals during fluidized bed combustion of sludge (FBSC), *Journal of Hazardous Materials*, **151**, 96-102.
- Ziolko D., Martin O.V., Scrimshaw M.D., Lester J.N. (2011), An Evaluation of Metal Removal During Wastewater Treatment: the Potential to Achieve More Stringent Final Effluent Standards, *Critical Reviews in Environmental Science and Technology*, **41**, 733-769.
- Zorpas A.A., Inglezakis V., Koumi C., Voukalli I., (2011), *Domestic sewage sludge (DSS) characteristics from wastewater treatment plant (WWTP) operation in warm climates conditions. A 7 years project*, Proc. 3rd International CEMEPE & SECOTOX Conference, June 19-24, 2011 Skiathos, Greece.